

For more than 30 years DC has been developing machines for the packaging industry. Together with strong partners like LECHITA AG we are able to customize machines according to customer requirements.

### What does that mean?

Our strength lies in working with our customers to find the best solution for them. This is reflected in the high level of satisfaction among our customers worldwide.

## Side Seal Bags

side seal with round corner



side seal v-shape

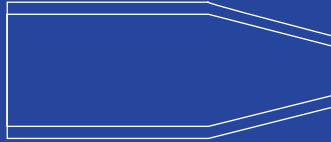

double bag

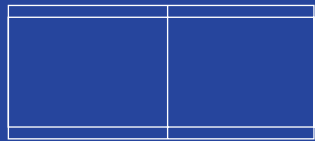

single bag

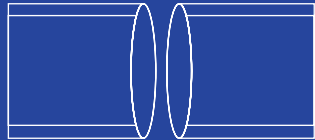

single bag on tape  
optional:  
double bag on tape



more information →  
[www.dold-consulting.com/lechita](http://www.dold-consulting.com/lechita)



+49 160 88 999 66

[info@dold-consulting.de](mailto:info@dold-consulting.de)

[www.dold-consulting.de](http://www.dold-consulting.de)

Elisabeth-Selbert-Straße 75  
87437 Kempten  
Germany



# YOUR GUIDE IN THE WORLD OF PACKAGING

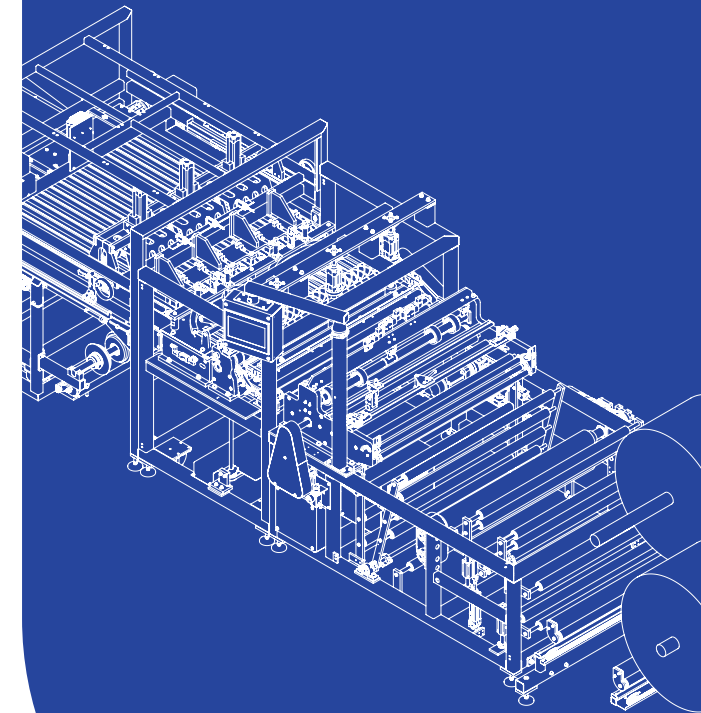

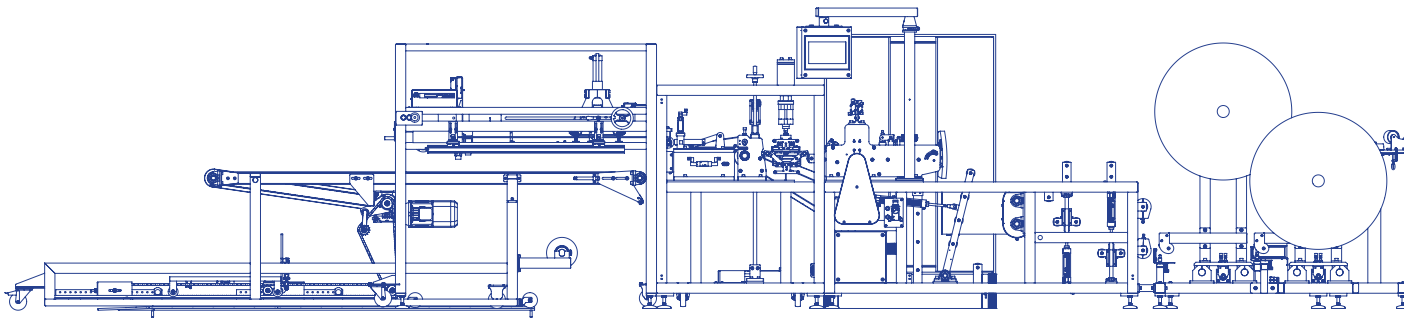

## Bottom Seal Bags

round (arc) bottom seal



V-bottom seal



straight bottom seal



boomerang seal



bullet seal



## Our Lechita machines

- Multifunctional Bag Machine DC 800
- SHBM 750 DC
- XL Shrink Bag Machine DC 1050
- Unfolding Unit DC 1

more information →  
[www.dold-consulting.com/lechita](http://www.dold-consulting.com/lechita)



SHBM 750 DC

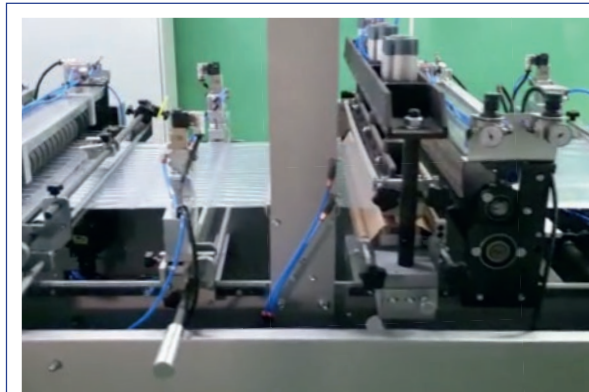

Multifunctional Bag Machine DC 800

bag on tape  
 on a roll with core



bag on a roll  
 with core



round (arc) bottom seal perforated  
 or taped bag on tape

